

- <sup>10</sup> Wills and Hawk, *THIS JOURNAL*, 36, 158 (1914).  
<sup>11</sup> Mattill and Hawk, *Ibid.*, 32, 1999 (1911).  
<sup>12</sup> Findlay, "Physical Chemistry and its Applications in Medicine and Biological Science," London, 1905.  
<sup>13</sup> Koeppel, *Deut. med. Woch.*, 1898, p. 624.  
<sup>14</sup> Harlow, Cited by Oehler.  
<sup>15</sup> Nocht, *Hyg. Rund.*, 1892, p. 273.  
<sup>16</sup> Winkler, *Z. physikal. diät. Ther.*, 8, 671 (1905).  
<sup>17</sup> Oehler, *Münch. med. Woch.*, 59, No. 50 (1912).  
<sup>18</sup> Howe, Mattill and Hawk, *J. Biol. Chem.*, 11, 103 (1912).

---

[FROM THE LABORATORIES OF PREVENTIVE MEDICINE AND HYGIENE, HARVARD MEDICAL SCHOOL.]

### A PIPETTOMETER.

By W. D. FROST.

Received June 16, 1914.

The pipettometer is a new piece of apparatus for measuring out precise amounts of fluids without the use of graduated pipets. It was originally intended for work in the bacteriological laboratory but will, no doubt, be found of interest to those working in other laboratories, such as those of chemistry, physics and medicine.

It consists essentially of an upright graduated glass tube with an upper side arm to which, by means of a piece of rubber tubing, ungraduated glass pipets may be readily attached. At the lower end of this graduated tube, another tube is attached by means of a flexible rubber joint. This tube has a bulb at the outer end and is so arranged that the bulb end can be readily raised or lowered. The upright tube and this movable arm with bulb are partially filled with mercury. The whole apparatus is supported on a wooden or metal frame which is so attached to a ring stand that its height can be varied. By moving the bulb up or down, the height of mercury column in the graduated upright can be raised or lowered. When the mercury is lowered in this tube, the pipet draws up the fluid into which its tip is immersed and when it is raised the fluid is forced out. The amount of fluid taken up or discharged is measured by reading the position of the mercury in the graduated upright.

The details of the construction and the use of the pipettometer can best be understood by reference to the accompanying figure.

A is the wooden or metal support with its short arm on the top and left C, while B is the longer arm on the right, hinged at the bottom. The whole is supported on a ring stand, D, to which it is held by the screw clamps ff. Mounted on this frame is the bent glass tube *abcd*, with a flexible joint at *c* and a bulb at *d*.

When the arm B is moved up to position I, the mercury stands at 1.0, and when it is lowered to II the mercury stands at 0. A graduated pipet,

*g*, is attached at *a* and the arm *B* is raised to I. A vessel containing the fluid to be drawn into it is brought to the point

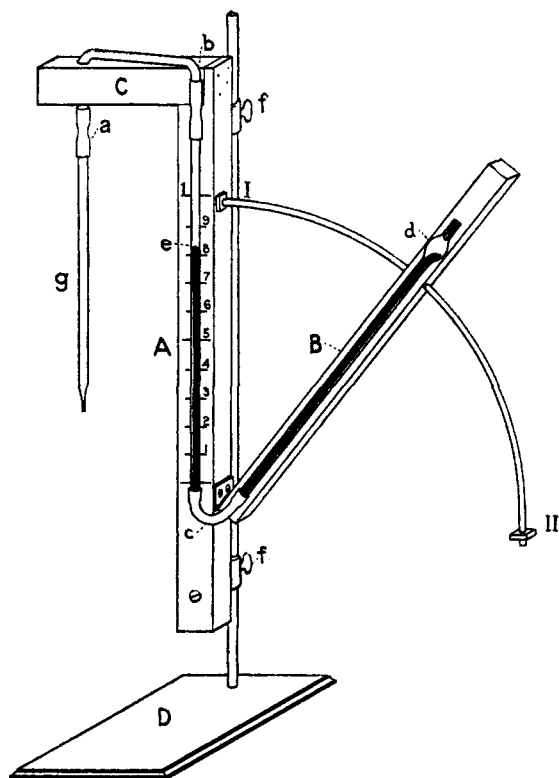

of the pipet and the arm *B* is lowered to II. In this way, the fluid is drawn into the pipet *g*. It can then be discharged in whole or in part by slowly raising the arm *B*. The amount discharged is indicated on the scale.

The graduations on the scale must be carefully made. This can be done by drawing water into *g* and then discharging it and weighing it on a fine balance. In this way the 0.5 and 1 cc. points can be determined. It will be accurate enough for ordinary work to mark off the intervening points. At first thought it might be supposed that all that it would be necessary to do would be to put a carefully graduated

pipet in the system between *b* and *c* but a little reflection will show that this would not be accurate, because the weight of the fluid in the pipet rarefies the column of air between the fluid in the pipet and of the column of mercury, so that not quite the proper amount of fluid is taken up. When, however, the graduations are once obtained, it is then possible to measure any fluid very accurately if it has practically the same specific gravity as the fluid used to make the graduations.

The apparatus was originally made to handle 1 cc. lots and it was found that, with a little practice, measured quantities could be handled as quickly and accurately as with graduated pipets.

The tube *bc* can be replaced by a very small tube, in which case hundredths of a cubic centimeter can be easily measured. Or it can be replaced by tubes of greater capacity which arrangement makes it convenient for measuring amounts of 10 cc. or more.

It can be used for handling poisonous or infectious material with great satisfaction, and can, furthermore, be readily used to calibrate pipets.

MADISON, WIS.

---

[CONTRIBUTION FROM THE WOLCOTT-GIBBS MEMORIAL LABORATORY OF HARVARD UNIVERSITY.]

## AN ADVANTAGEOUS FORM OF STILL FOR THE EXACT MEASUREMENT OF BOILING POINT DURING FRACTIONAL DISTILLATION.

BY THEODORE W. RICHARDS AND FREDERICK BARRY.

Received June 8, 1914.

In the course of a recent investigation on the heats of combustion of liquid hydrocarbons, it was needful to prepare certain of these substances in a very high degree of purity, and at the same time in considerable quantity. For this work it was necessary to determine exact boiling points, and an advantageous form of still was devised, which proved itself, especially in this respect, more efficient than any of the apparatus now in common use. This still, because of its simplicity and usefulness, and because it does not appear to have been proposed before, seems to the authors to merit separate brief description.

In the accompanying drawing, two forms of the instrument are shown. Fig. 1 represents the type first constructed: of this the other is a simple modification. A glance will show the immediate purpose of the device. The still was designed to hold a sensitive Beckmann thermometer, so that very small fluctuations in the boiling point of the liquid under examination could be accurately observed, and the boiling point of the purest distillate precisely determined by a comparison with a standard vapor of neighboring known boiling point. The still not only served this purpose admirably, but proved itself (as had been expected) a very effective instrument for fractionation, without being further modified.

It consists essentially of a flask, of any desired capacity within practicable limits, to which a side tube is attached, the latter being held parallel to the neck of the flask, and connected with it, by two smaller tubes at the top and bottom. The upper of these (which serves to carry the outgoing vapor) communicates directly with the upper end of the flask-neck; while the lower tube, which serves to return the prematurely condensed liquid to the flask, is a constricted continuation of the side tube itself, and is bent into a shallow U, fused into the flask-neck a few centimeters above the bulb. The relative positions and sizes of these tubes are shown in the drawing (Fig. 1). The lower connecting U-tube should be very narrow in diameter, and bent in such a way that the orifice at the flask-neck is not much more than the tube's diameter above its lowest point, so as to minimize the amount of dead space which can hold and thereby waste the liquid being distilled.